

This pump enables easy pressure generation up to 700 bar. As pressure media acts either hydraulic oil or water. The reservoir contains approx. 100 cm³ allowing to fill higher dead volumes. The pump incorporates a fine adjustment- and shut off valve and is very well suited for the testing of manometers and pressure transmitters. The pump is delivered in a solid carrying case, including the corresponding adapters.

- a** G 1/4" female connection to take master instruments e.g. Lex 1, Leo 1, Leo 2 and Intelligent Manometers
- b** Pressure release valve
- c** Fine control
- d** Front port: G 1/4" female to take optional Quick-fit connection and flexible hose
- e** 100 cc's reservoir
- f** Reservoir filling plug
- g** Priming/high pressure selector
- h** Fluid inlet tube
- i*** Rear port: Pressure relief valve (do not use for any other purpose)

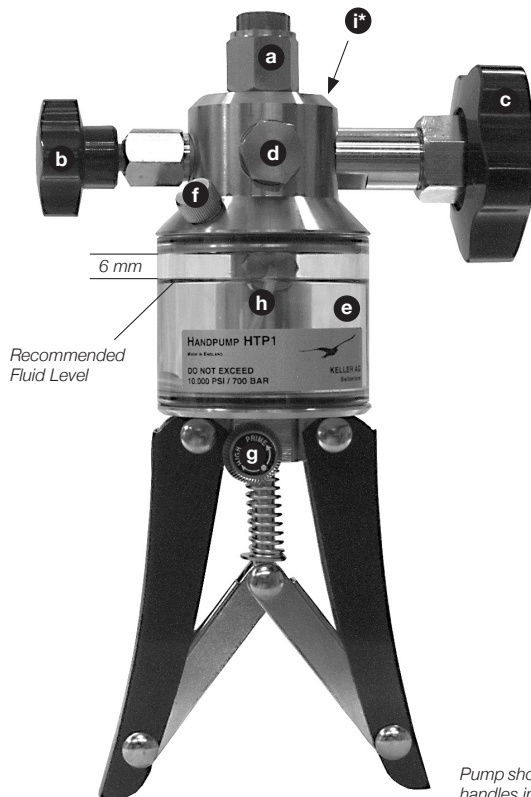

Specification:

Pressure range:	0...700 bar maximum
Pressure media:	Mineral based Hydraulic Oil (DW 6292) Distilled water
Pressure connections:	2 x G 1/4" female
Dimensions:	255 mm (L) x 176 mm (W) x 70 mm (D)
Weight:	approx. 1,7 kg
Adapters included in delivery:	Nr. 1 = G 1/4" – G 1/8" Nr. 2 = G 1/4" – 1/8" NPT Nr. 3 = G 1/4" – 1/4" NPT Nr. 4 = G 1/4" – G 3/8" Nr. 5 = G 1/4" – 3/8" NPT Nr. 6 = G 1/4" – G 1/2" Nr. 7 = G 1/4" – 1/2" NPT

Master Instruments available to suit HTP1 Hydraulic Hand Pump:

LEX 1

Accuracy: 0,05%FS



Intelligent Manometer

Accuracy: 0,1%FS



LEO 1

Accuracy: 0,2%FS



LEO 2

Accuracy: 0,1%FS



Please request the specific datasheet for further information about these products or visit our website.

Instructions for use of Hydraulic Hand Pump HTP1

Please read these instructions carefully prior to setting up and using the Hand Pump. The pressure built up internally during use can be extremely high. Ensure that all connections are made correctly.

1. Remove filling plug (f) and fill reservoir (e) to the recommended level with the appropriate fluid and replace plug.
2. Connect master instrument to pump via connection (a) using the appropriate seals.
3. Mount Quick-fit connection and flexible hose to the pump (d) and connect the unit to be tested to the hose.
4. Adjust the fine control (c) to "mid-travel".
5. Ensure the pressure release valve (b) is **open**. Fully squeeze handles "in" and turn the selector (g) to the "prime" position.
6. Operate handles several times to expel air from the pump. (Ensure that the fluid inlet tube (h) remains immersed in fluid at all times).
7. Close the release valve (b) fully.
8. Prime system by squeezing handles together and then releasing, allowing the oil to enter the pump cylinder. Repeat as necessary until system is fully primed and low pressure is indicated on either the master or test instrument.
9. With handles fully squeezed "in" select the "high" pressure position on selector (g) and operate handles to generate approximate pressure.
NOTE: Smaller handle strokes enable easier pressure generation at high pressures.
10. Adjust pressure to required value using the fine control (c).
NOTE: Pressure will fall slightly, immediately after pressure generation due to thermodynamic effects, but will stabilise after a short time.
WARNING: DO NOT EXCEED MAX. OPERATING PRESSURE OF 700 bar (10'000 PSI).
11. To totally release pressure from the system turn release valve (b) one turn anticlockwise and select the "prime" position on selector (g) after first squeezing handles fully in.
NOTE: Careful use of the fine control (c) and release valve (b) enables a controlled release of pressure, essential for calibration purposes.
12. RESERVOIR FLUID LEVEL: If the fluid level in the reservoir falls considerably during use, a partial vacuum can be created in the reservoir which may affect the pump performance. To avoid this, simply allow air to enter the reservoir by partly unscrewing the filling plug (f).
13. SEAL REPLACEMENT: Dependant on the frequency of use, the main piston seal (and others) will need replacing. Replacement seals and instructions for fitting are contained in the seal set.

www.keller-druck.com